

F-SERIES BODY INSTALLATION FOR CREW CAB OUTER ROCKER PANEL REINFORCEMENT - SERVICE KIT INSTRUCTIONS

KIT		
Part Number	Description	Quantity
FL34-1610142-AB	Outer Rocker Panel Reinforcement Forward (RH) - Crew Cab	1
SKFL34-1610142-AA	Instruction Sheet	1

KIT		
Part Number	Description	Quantity
FL34-1610402-AB	Outer Rocker Panel Reinforcement Rear (RH) - Crew Cab	1
SKFL34-1610142-AA	Instruction Sheet	1

KIT		
Part Number	Description	Quantity
FL34-1610143-AB	Outer Rocker Panel Reinforcement Forward (LH) - Crew Cab	1
SKFL34-1610142-AA	Instruction Sheet	1

KIT		
Part Number	Description	Quantity
FL34-1610403-AB	Outer Rocker Panel Reinforcement Rear (LH) - Crew Cab	1
SKFL34-1610142-AA	Instruction Sheet	1

NOT INCLUDED IN KIT (PROCURE LOCALLY)		
Part Number	Description	Quantity
W702512-S900C	Blind Rivet	21
W708777-S900C	Blind Rivet	7
W710246-S900	Self-Piercing Rivet (SPR) Code DB	5
Motorcraft TA-1, 3M 8115 or Fusor 108B	Metal Panel Bonding Adhesive	1



SERVICE GUIDELINES:

- Aluminum repairs should be performed in an area protected from steel working areas, and tools used in aluminum repair should be quarantined from steel repair tools.
- Replacement Self-Piercing Rivets (SPRs) are the preferred replacement during repair for original SPR locations, where feasible. Blind rivets are the next preferred replacement for original SPRs. In some cases, solid rivets may also be used as a replacement for SPRs. The figures will explicitly call out which rivets are possible.
- Replacement SPRs are to be installed adjacent to original SPR location.

NOTE: Do not install replacement SPR in original SPR hole.

- Blind rivets may be installed in original SPR holes, after they are reamed out to 6.5mm. Be sure to grind all surfaces of the flange smooth prior to blind rivet installation in original SPR locations.
- Flow Drill Screws (FDS) are to be replaced by blind rivets only. The original location of the FDS is used, but reamed out to 6.5mm.
- Rivets may be removed by drilling, grinding, or SPR gun set up as a rivet removal tool.
- Using heat (not exceeding 425 °F) to loosen a rivet bonded panel should only be done when all panels in the joint will be replaced or separated and new adhesive applied.
- Flange preparation for adhesive is to grind to clean metal with 80-120 grit, clean, and then apply the adhesive, spreading it out with an acid brush, covering any exposed aluminum.
- Clecos are an excellent way to hold the panels into position when fitting and drilling rivet holes.



- (Refer to Figure 1) for optional five (5) SPR rivets (W710246-S900) Code DB, Mandrel DP10-200H.
- Black triangles represent the location of seven (7) rivets (W708777-S900C) (Refer to Figure 1).

SQUARED NUMBERS ARE PRO SPOT MANDRELS	
1	SA-0400/SA-0401
2	SA-0400/SA-0402

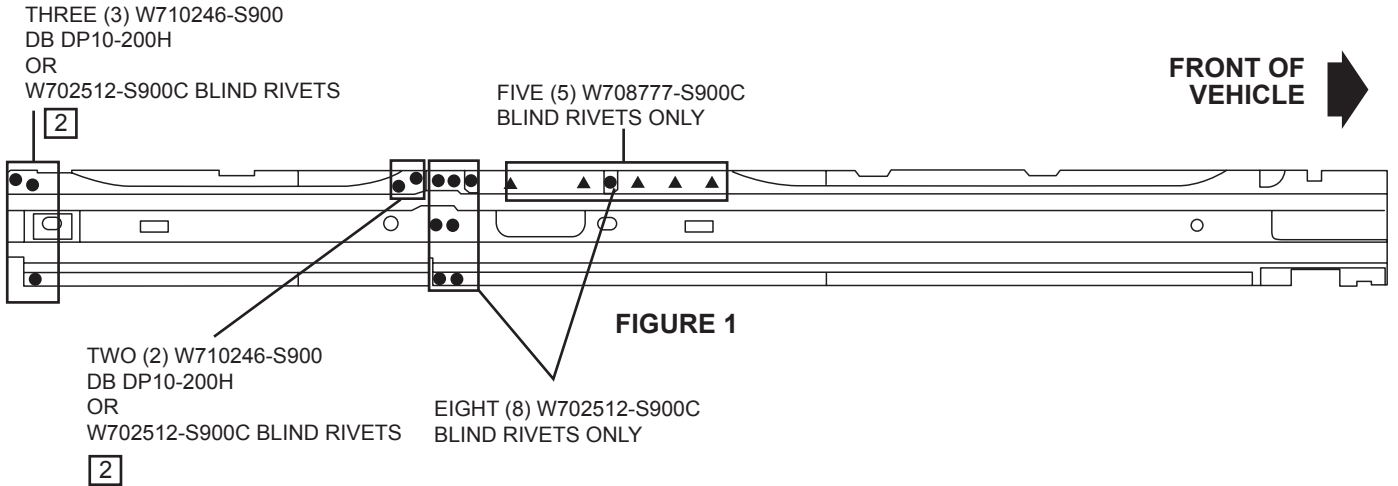

- (Refer to Figure 4) for location for adhesive material.

NOTE: The location of SPR and adhesive shown below are based on the original production drawings and should only be used as a guideline.

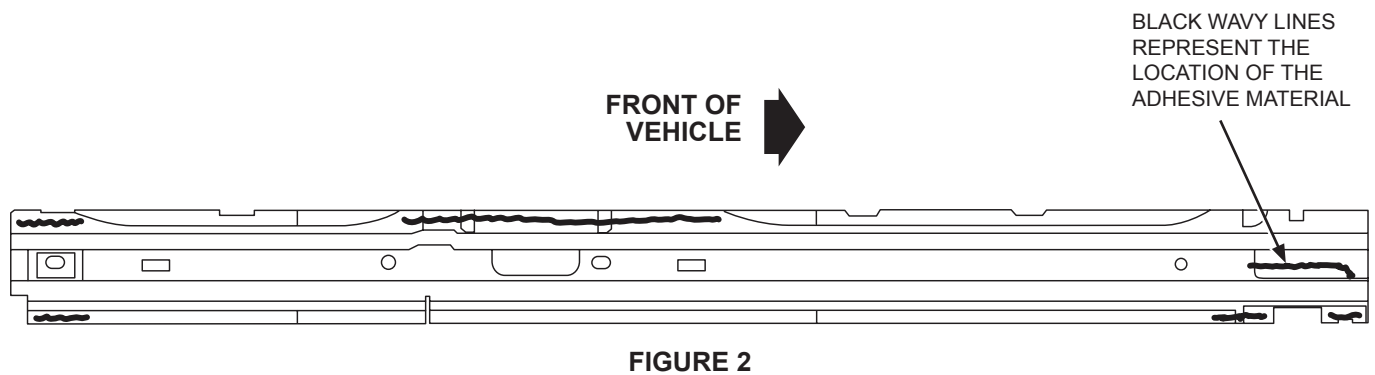

SKFL34-1610142-AA

SHEET 3 OF 3



CPR © 2014 FORD MOTOR COMPANY
DEARBORN, MICHIGAN 48121
10-14

F-SERIES BODY INSTALLATION FOR CREW
CAB OUTER ROCKER PANEL REINFORCEMENT -
SERVICE KIT INSTRUCTIONS